



Magnetic Product Selection Guide

Contents

Switch position detects IC

Vertical induction

High voltage and high speed series	4
Low voltage high speed series	4
Low voltage and low power series	4
Micropower series	5
Dual output series	5

Planar induction

Reluctance induction switch	6
-----------------------------	---

Current detection and linear displacement detection IC

Current sensor

External magnetic circuit type	7
Built-in magnetic circuit type	7

Linear displacement sensor

Factory programming series	8
On-line programming series	9

Plane Angle detection IC

Shaft mounting





Magnetic Angle sensing element	11
Low speed magnetic Angle coding	11
High speed magnetic Angle coding	12
On-line programming Angle location	14

Off-shaft mounting

Off-axis magnetic Angle coding	15
--------------------------------------	----

Encapsulation form

Encapsulation form	16
--------------------------	----



Switch position detects IC

- Two principles of sensing effect

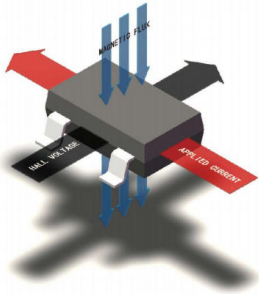

Hall effect induction principle

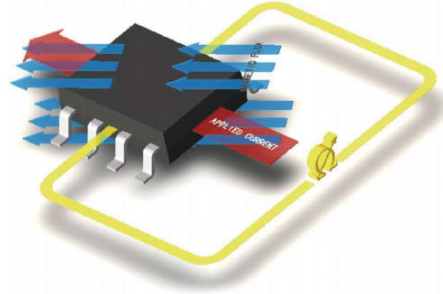

Principle of reluctance effect induction

- Three polarity sensing methods

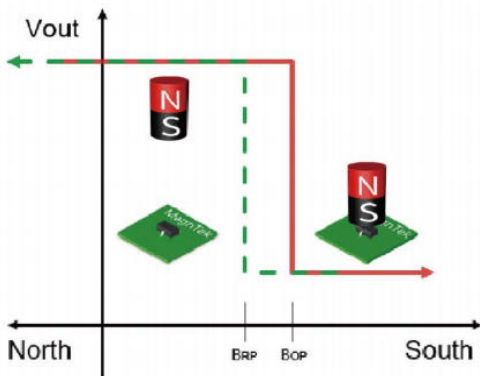

Uni-polar induction type

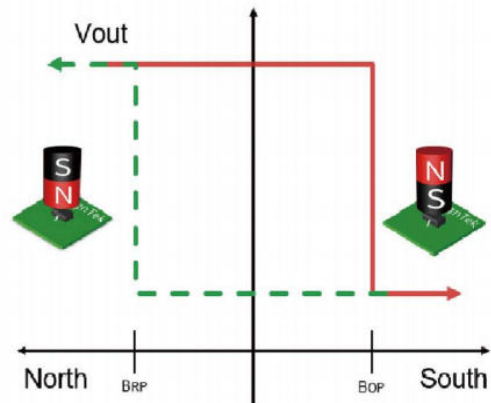

Latch induction type

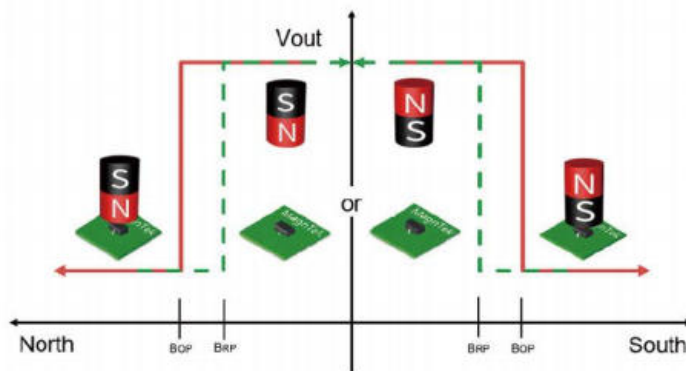

Omni-polar induction type

Vertical induction

- High pressure and high speed series products

This series of products uses the BCD process, integrated with Hall induction components in the chip. With a wide range of operating voltage (3.8~60V) and good reverse voltage protection ability and overcurrent protection ability, 200KHz sampling frequency. And has excellent temperature compensation, using the chip can work in -40~150 environment, and maintain good performance and consistency.

Recommended application: Auto gear shifters, auto air conditioners, windshield wipers, etc.

Product model	Type	Sampling frequency (Hz)	Supply voltage (V)	Power Consumption (mA)	Operating Temperature ()	Point (Gs)	Release point (Gs)	Output form	Encapsulation form
CC8311	Single-pole switch	200K	3.8~60	4.0	-40~150	140	105	Leak-open output	Small SOT-23,SOT-23,Flat TO-92
CC8312	Single-pole switch	200K	3.8~60	4.0	-40~150	255	210	Leak-open output	Small SOT-23,SOT-23,Flat TO-92
CC8313	Single-pole switch	200K	3.8~60	4.0	-40~150	85	50	Leak-open output	Small SOT-23,SOT-23,Flat TO-92
CC8315	Single-pole switch	200K	3.8~60	4.0	-40~150	30	20	Leak-open output	Small SOT-23,SOT-23,Flat TO-92
CC8361	Pole locking switch	200K	3.8~60	4.0	-40~150	50	-50	Leak-open output	Small SOT-23,SOT-23,Flat TO-92
CC8362	Pole locking switch	200K	3.8~60	4.0	-40~150	20	-20	Leak-open output	Small SOT-23,SOT-23,Flat TO-92
CC8381	Pole locking switch	200K	3.8~60	4.0	-40~150	50	-50	Built-in 10K pull-up resistor	Small SOT-23,SOT-23,Flat TO-92
CC8382	Pole locking switch	200K	3.8~60	4.0	-40~150	20	-20	Built-in 10K pull-up resistor	Small SOT-23,SOT-23,Flat TO-92

- Dual output

Built-in two Hall induction IC, and maintain a fixed distance, so that the output signals of the two phase difference, not only can be a speed signal can be obtained, but also by judging the front and rear phase of the two speed signals can be judged direction.

Recommended application: Auto doors and Windows/sunroof anti-clamp, auto electric tail door opening and closing, auto seat position adjustment, communication base station antenna Angle adjustment.

Product model	Type	Sampling frequency (Hz)	Supply voltage (V)	Power Consumption (mA)	Operating Temperature ()	Point (Gs)	Release point (Gs)	Output form	Encapsulation form
CC8901-SD	Pole locking switch	100K	2.7~24	4.5	-40~150	25	-25	Velocity + direction	SOT-23-6L,Flat TO-92
CC8901-SS	Pole locking switch	100K	2.7~24	4.5	-40~150	25	-25	Velocity + direction	SOT-23-6L,Flat TO-92

CC8902-SD	Pole locking switch	100K	2.7~24	4.5	-40~150	25	-25	Velocity + direction	SOT-23-6L,Flat TO-92
CC8902-SS	Pole locking switch	100K	2.7~24	4.5	-40~150	25	-25	Velocity+Velocity	SOT-23-6L,Flat TO-92
CC8911-DUAL	Single-pole switch	100K	2.7~24	4.5	-40~150	140	105	Double channel leak	SOT-23-6L,Flat TO-92
CC8911-DUAL	Single-pole switch	100K	2.7~24	4.5	-40~150	255	210	Double channel leak	SOT-23-6L,Flat TO-92

Low-voltage and high-speed series products

This series of products uses the BCD process, integrated with Hall induction components in the chip. Up to 24V operating voltage, with reverse voltage protection and overcurrent protection, not less than 100KHz sampling frequency. And has excellent temperature compensation, so that the chip can work in -40~150 environment, and maintain good performance and consistency.

Recommended application: Electric bike, electric car, white goods, etc.

Product model	Type	Sampling frequency (Hz)	Supply voltage (V)	Power Consumption (mA)	Operating Temperature ()	Point (Gs)	Release point (Gs)	Output form	Encapsulation form
CC8111	Pole locking switch	400K	2.8~24	3.5	-40~150	110	85	Leak-open output	Small SOT-23,SOT-23,Flat TO-92
CC8161	Pole locking switch	400K	2.8~24	3.5	-40~150	20	-20	Leak-open output	Small SOT-23,SOT-23,Flat TO-92
CC8162	Pole locking switch	400K	2.8~24	3.5	-40~150	60	-60	Leak-open output	Small SOT-23,SOT-23
CC8911	Single-pole switch	100K	2.7~24	4.5	-40~150	140	105	Leak-open output	SOT-23
CC8912	Single-pole switch	100K	2.7~24	4.5	-40~150	255	210	Leak-open output	SOT-23
CC8962	Pole locking switch	100K	2.7~24	4.5	-40~150	25	-25	Leak-open output	Small SOT-23,SOT-23
CC8181	Pole locking switch	400K	2.8~24	3.5	-40~150	20	-20	Built-in 10K pull-up resistor	Small SOT-23,SOT-23,Flat TO-92
CC1401-EN	Pole locking switch	400K	2.8~24	2.3	-40~150	24	-24	Leak-open output	Small SOT-23,SOT-23,Flat TO-92
CC3411-EN	Pole locking switch	400K	2.8~24	2.3	-40~150	24	-24	Built-in 10K pull-up resistor	SOT-23,Flat TO-92
CC4409-EN	Pole locking switch	400K	2.8~24	4.25	-40~150	45	-45	Leak-open output	Flat TO-92
CC3303-EN	All-pole switch	400K	2.8~24	2.3	-40~150	±150	±120	Leak-open output	SOT-23,Flat TO-92
CC8762	Pole locking switch	100K	3.8~60	1.2	-40~150	20	-20	Leak-open output	Small SOT-23,SOT-23,Flat TO-92

Low-voltage and low-power series products

This series of products uses the BCD process, integrated with Hall induction components in the chip. The maximum working voltage is 24V, and the maximum working current is 1.0mA at the sampling frequency of not less than 15K. At the same time, the chip has good reverse voltage protection ability and overcurrent protection ability, and has excellent temperature compensation, so that the chip can work in -40~125 and -40~150 two different temperature ranges, and maintain good performance and consistency. It is espe-



cially suitable for position detection which needs to strike a balance between high sampling frequency and low power consumption.

Recommended application: Electric curtain, micro brushless DC motor, automobile electric suction door, small household appliances, etc.

Product model	Type	Sampling frequency (Hz)	Supply voltage (V)	Power Consumption (mA)	Operating Temperature ()	Point (Gs)	Release point (Gs)	Output form	Encapsulation form
CC8511	Single-pole switch	25K	3.0~24	1.0	-40~150	28	18	Leak-open output	Small SOT-23,SOT-23,Flat TO-92
CC8512	Single-pole switch	25K	3.0~24	1.0	-40~150	120	90	Leak-open output	Small SOT-23,SOT-23,Flat TO-92
CC8562	Pole locking switch	25K	3.0~24	1.0	-40~150	20	-20	Leak-open output	Small SOT-23,SOT-23,Flat TO-92
CC8571	All-pole switch	25K	3.0~24	1.0	-40~125	± 32	± 27	Built-in 10K pull-up resistor	SOT-23,Flat TO-92
CC8572	All-pole switch	25K	3.0~24	1.0	-40~125	± 80	± 60	Built-in 10K pull-up resistor	SOT-23,Flat TO-92
CC8573	All-pole switch	25K	3.0~24	1.0	-40~125	± 60	± 40	Built-in 10K pull-up resistor	SOT-23,Flat TO-92
CC8551	All-pole switch	25K	3.0~24	1.0	-40~125	± 32	± 27	Leak-open output	SOT-23,Flat TO-92
CC8552	All-pole switch	25K	3.0~24	1.0	-40~125	± 80	± 60	Leak-open output	SOT-23,Flat TO-92
CC8553	All-pole switch	25K	3.0~24	1.0	-40~125	± 60	± 40	Leak-open output	SOT-23,Flat TO-92
CC8711	Single-pole switch	15K	2.4~24	0.6	-40~150	85	55	Leak-open output	Small SOT-23,SOT-23,Flat TO-92
CC8712	Single-pole switch	15K	2.4~24	0.6	-40~150	130	100	Leak-open output	Small SOT-23,SOT-23,Flat TO-92
CC8713	Single-pole switch	15K	2.4~24	0.6	-40~150	30	20	Leak-open output	Small SOT-23,SOT-23,Flat TO-92
CC8763	Pole locking switch	15K	2.4~24	0.6	-40~150	20	-20	Leak-open output	Small SOT-23,SOT-23,Flat TO-92

■ Micro power consumption series products

This series of products uses CMOS technology and integrates Hall induction components into the chip. The minimum working voltage is 1.6V, and 1.7uA ultra-low power consumption, and has excellent temperature compensation, so that the chip can work in the environment of -40~125 and -40~85 , further improve the product consistency and anti-interference ability.

Recommended application: Smart water meter/electricity meter/gas meter, smart door lock, TWS Bluetooth headset, convenient juicer cup, sweeping robot, etc.

Product model	Type	Sampling frequency (Hz)	Supply voltage (V)	Power Consumption (mA)	Operating Temperature ()	Point (Gs)	Release point (Gs)	Output form	Encapsulation form
CC8631	All-pole switch	20	2.0~5.5	1.2	-40~125	± 37	± 25	Push-pull output	SOT-23,Flat TO-92,DFN1616
CC8632	All-pole switch	20	2.0~5.5	1.2	-40~125	± 15	± 9	Push-pull output	SOT-23,Flat TO-92
CC8633	All-pole switch	20	2.0~5.5	1.2	-40~125	± 10	± 6	Push-pull output	SOT-23,Flat TO-92

CC8651	All-pole switch	20	2.0~5.5	1.2	-40~125	± 37	± 25	Leak-open output	SOT-23,Flat TO-92
CC8652	All-pole switch	20	2.0~5.5	1.2	-40~125	± 16	± 9	Leak-open output	SOT-23,Flat TO-92
CC8691	Single-pole switch	20	2.0~5.5	1.2	-40~125	35	25	Push-pull output	SOT-23,Flat TO-92 DFN1608,DFN1616
CC8831	All-pole switch	20	1.6~5.0	1.7	-40~85	± 30	± 20	Push-pull output	SOT-23,Flat TO-92 DFN1608,DFN1616
CC8891	Single-pole switch	20	1.6~5.0	1.7	-40~85	30	20	Push-pull output	SOT-23,Flat TO-92 DFN1608,DFN1616
CC8822	Latch switch	20 (Ctrl=I;1.2KHz)	1.6~5.0	1.7 (Ctrl=I;60uA)	-40~85	20	-20	Push-pull output	DFN1616
CC8822	Latch switch	1.2KHz	1.6~5.0	60uA	-40~85	20	-20	Push-pull output	SOT-23

Macro detection products

CC8001 chip is the latest micro range magnetic detection chip launched by Banning Sensing, which is designed and developed based on high sensitivity Hall. CC8001 Magnetic Hall magnetic sensor can communicate with I²C, output 12 precision vertical magnetic field strength signal value, and provide editable signal gain and signal bias magnetic field calibration function, so that it can be used in a variety of position detection applications.

Recommended application: TWS Bluetooth headset, stylus, VR controller, gaming controller

Product model	Type	Supply voltage (V)	Power consumption (mA)	Operating temperature ()	Output form	Encapsulation form
CC8001	CMOS	2.6V~5V	< 5uA sleep 2.8mA awake	-20~85	Open leakage output & I2C communication	DFN1616

Planar induction

Reluctance switch products

The AMR bridge resistance, which changes in impedance value depending on the strength and Angle of the parallel passing magnetic field, is integrated with the ASIC in a single chip. Non-contact position detection is carried out by matching with magnet. Compared with Hall sensor, it has higher accuracy (the return difference can be less than 3 Gauss), parallel induction to magnetic field, and achieves 360 degree two-dimensional induction with AWR bridge resistance in different directions. Mainly used in different induction Angle and ground high frequency induction applications, there are two product lines, one-dimensional induction switch and two-dimensional induction switch.

Reluctance one-dimensional induction switch



Built-in single AMR bridge resistance, to achieve the detection of magnetic field within an Angle of $\pm 25^\circ$

It is typically used for accurate detection where remanence interference is required.

Recommended application: Industrial cylinder stroke position detection, intelligent water meter and gas meter flow count and anti-magnetic attack detection.

Product model	Type	Sampling frequency (Hz)	Supply voltage (V)	Power Consumption (mA)	Operating Temperature ()	Point (Gs)	Release point (Gs)	Output form	Encapsulation form
CC6325	All-pole switch	900	1.8~5.5	4.1	-40~125	± 17	± 14	Push-pull output	DFN1616
CC6325-L	All-pole switch	900	1.8~5.5	4.1	-40~125	± 47	± 38	Push-pull output	DFN1616
CC6341	All-pole switch	20	1.8~5.5	1.3	-40~125	± 10	± 8	Push-pull output	SOT-23,Flat TO-92
CC6342	All-pole switch	20	1.8~5.5	1.3	-40~125	± 18	± 15	Push-pull output	SOT-23,Flat TO-92

■ Reluctance two dimensional induction switch

The built-in multi-channel AMR bridge stop can realize the detection of 360° planar magnetic field by placing it at different angles. It is typically applied to the location detection of magnetic field requiring large induction Angle.

Recommended application: Industrial liquid level position detection, smart meter anti-magnetic attack detection.

Product model	Type	Sampling frequency (Hz)	Supply voltage (V)	Power Consumption (mA)	Operating Temperature ()	Point (Gs)	Release point (Gs)	Output form	Encapsulation form
CC6131	All-pole switch	20	1.65~5.0	2	-40~125	± 18	± 13	Push-pull output	SOT-23
CC6132	All-pole switch	1K	1.65~5.0	15	-40~125	± 18	± 13	Push-pull output	SOT-23
CC6133	All-pole switch	20	1.65~5.0	2	-40~125	± 18	± 13	Leak-open output	SOT-23

Current detection and linear displacement detection IC

Current sensor

■ External magnetic circuit IC

This series of sensors is based on Hall induction technology and is specialized for current sensor applications.

The integrated temperature compensation circuit can control the temperature drift of the chip's median voltage and sensitivity within a very small error range. With external ferromagnetic core (ferrite, silicon steel), can be designed for the induction of 0~3000A and above current applications. Output voltage signal proportional to the magnitude of the magnetic field generated by the measured current. With special programmer and internal integration EEPROM, users can easily according to the actual current size, sensitivity of custom programming (0.6~22.624mV/Gs); The number of repeated erases is not less than 200 times.

Recommended application: Photovoltaic, welding machine, uninterrupted power supply, battery management system, vehicle inverter, etc.

Product model	Operating voltage (V)	Power consumption (mA typ.)	Bandwidth (KHz)	Response time (us)	Operating temperature ()	Linearity (% typ.)	Sensitivity programming range (mV/Gs)	Static output (V)	Encapsulation form
CC9211	4.5~5.5	10	150	< 4	-40~150	< ± 0.2	0.707~22.624	50%Vcc	Flat TO-94
CC9511	4.5~5.5	12	250	< 2.2	-40~150	< ± 0.2	0.6~22.6	50%Vcc	Flat TO-94
CC9512	4.5~5.5	12	250	< 2.2	-40~150	< ± 0.2	0.6~22.6	2.5V	Flat TO-94

▪ Built-in magnetic circuit IC

This series is a built-in magnetic circuit type current detection chip. The principle is to integrate the "current-magnetic" conversion module into the chip, using the Hall effect principle, and then convert the magnetic signal into the voltage output signal proportional to the input current. The series features superior dielectric strength (SOP-8 > 2400Vrms, SOP16W > 4800Vrms), "zero" hysteresis and ultra-high speed us class response time, which are ideal for current detection and overcurrent protection in various inverters/converters. The integrated temperature compensation circuit of the series can control the static output voltage of the chip and the temperature drift of the sensitivity within a very small error range. With the built-in current loop, it can easily achieve 0~ ± 100A current detection applications.

Recommended application: Uninterruptible power supply, car charger, power supply, portable energy storage, universal frequency converter, servo driver, photovoltaic inverter, etc

Product model	Current type	Static output (V)	Measuring range (A)	Source side resistance (m Ω)	Dielectric strength (V)	Creepage distance (mm)	Operating voltage (V)	Power consumption (mA)	Temperature range (°C)	Encapsulation form
CC9221	AC DC	50% V _{cc} 10% V _{cc}	0~ \pm 30	1.5	2600V	4	4.5~5.5	14	-40~125	SOP-8
CC9222	AC DC	50% V _{cc} 10% V _{cc}	\pm 20~ \pm 100A	0.85	4800V	8.2	4.5~5.5	14	-40~125	SOP-16W
CC9223	AC DC	50% V _{cc} 10% V _{cc}	0~ \pm 50	1.2	2400V	4	4.5~5.5	14	-40~125	SOP-8
CC9522	AC DC	50%V _{cc} /10%V _{cc} 2.5V/1.65V/0.5V	0~ \pm 80A	0.75	4800V	8.2	3~3.6/4.5~5.5	13/15	-40~125	SOP-16W
CC9523	AC DC	50%V _{cc} /10%V _{cc} 2.5V/1.65V/0.5V	0~ \pm 50A	1	2500V	4	3~3.6/4.5~5.5	13/15	-40~125	SOP-8
CC9532	AC DC	50%V _{cc} /10%V _{cc} 2.5V/1.65V/0.5V	0~ \pm 80A	0.75	4800V	8.2	3~3.6/4.5~5.5	22/24	-40~125	SOP-16W

Linear displacement sensor

- Factory programmed linear Hall IC

The output sensitivity and the median value of output zero are fixed. It has the advantages of simple application and low cost.

Product model	Type	Operating voltage (V)	Power consumption (mA)	Bandwidth (KHz)	Sensitivity (mV/Gs)	Magnetic field range (Gs)	Temperature range (°C)	Encapsulation form
CC9101	Linear simulation	3.0~5.5	6.7	30	1.5	\pm 1466	-40~150	SOT-23,Flat TO-92S,DFN1616
CC9102	Linear simulation	3.0~5.5	6.7	30	2.5	\pm 880	-40~150	SOT-23,Flat TO-92S,DFN1616
CC9103	Linear simulation	3.0~5.5	6.7	30	3.4	\pm 650	-40~150	SOT-23,Flat TO-92S,DFN1616
CC9105	Linear simulation	3.0~5.5	6.7	30	5.0	\pm 440	-40~150	SOT-23,Flat TO-92S,DFN1616

- Current sensor module

The CC921 product family is an open-loop current sensor module based on the Hall effect principle, which can be used for AC or DC detection in a wide range of industrial, commercial and communication systems. Each CC921 consists of a high precision, low noise, low temperature drift linear Hall IC, magnetic core, and built-in current conductor path with low insertion resistance. The applied current flowing through the path of a low-resistance current conductor creates a magnetic field, which the chip converts into a voltage signal output proportional to the input current. Because of the use of magnetic core inside the module, it can effectively suppress the interference of external common mode magnetic field to the module, and improve the accuracy in the magnetic field environment.

Product model	Static output (V)	Measuring range (A)	Source side resistance (m Ω)	Dielectric strength (ms)	Operating voltage (V)	Power (mA)	Bandwidth (kHz)	Response time (us typ.)	Tem. range (°C)	Linearity	Encapsulation form
CC921-xxB5	50% Vcc	0~ ±200A	0.1	4800V	4.5~5.5	10	150	< 4	-40~125	< ± 0.3%	CB-2-3
CC921-xxU5	10% Vcc	0~200A	0.1	4800V	4.5~5.5	10	150	< 4	-40~125	< ± 0.3%	CB-2-3
CC952CA	2.5V	0~ ± 50A	0.21	4800V	4.5~5.5	10	150	< 2.5	-40~105	< ± 0.3%	CA-2-4

Plane Angle detection IC

Shaft mounting

- Magnetic Angle sensing element

Based on anisotropic magnetoresistive material (AMR) technology, magnetic induction components with excellent performance of high sensitivity, low misalignment and high linearity can be developed into Angle control modules to provide a wide range of high-performance non-contact rotation Angle control solutions for industrial, medical and consumer sectors.

Recommended application: Magnetic encoder module, rotation Angle control, etc.

	CC611	CC631
Operating voltage (VCC)	VCC<12V	VCC<12V
Operating temperature range	-40~125	-40~125
Induced magnetic field requirement	>20mT	>20mT
Measuring range	0~180 °	0~180 °
Offset voltage (Vos)	-2<Vos<2mV/V	-0.3<Vos<0.3mV/V
Offset voltage temperature drift (Vosd) (-40~125 °C)	-300<Vos<300uV/V	-300<Vos<300uV/V
Typical peak-to-peak value of output @VCC=5V	115mV	120mV
Peak-peak temperature drift (-40~125 °C)	-3300ppm/	-3300ppm/
Orthogonal error (OE)	-1 ° <OE<1 °	-1 ° <OE<1 °
Compensated angular accuracy (INL) (typical value)	-1 ° <INL<1 °	-1 ° <INL<1 °
Bridge resistance	1K	1K
Bridge resistance temperature (-40~125 °C)	2800ppm/	2800ppm/
Encapsulation form	SOP-8	SOP-8

▪ Low speed magnetic Angle coding IC

Low speed magnetic Angle coding IC integrates high precision AMR sensor and special decoding chip, which can realize the Angle detection accuracy within $\pm 1^\circ$. The minimum package of 3mm*3mm can adapt to the small size requirements of most applications. At the same time, the non-contact magnetic induction control has high reliability, the maximum temperature range reached -40~125, with the traditional ABZ/UVW incremental output and analog output and I2C, SPI, PWM and other output interfaces.

Recommended application: Gimbal, robot joint control, stepping motor control, etc.

	CC611	CC613	CC6815
Operating voltage (VCC)	3.3~5.5V	3.3~5.5V	3.3~5.5V
Induced magnetic field requirement	> 20mT	> 20mT	> 20mT
Measuring range	0~360 °	0~360 °	0~360 °
Power consumption	5.5mA	6mA	6mA
Operating temperature	-40~125	-40~125	-40~125
Linearity INL (typical value)	-1.5 ° <INL<1.5 °	-1.2 ° <INL<1.2 °	-1.0 ° <INL<1.0 °
System delay	100us	100~400us	100~400us
Maximum support speed	<6000 RPM	<6000 RPM	<6000 RPM
ABZ incremental output	8~12bit	-	8~12bit 100/200/500/1000
UVW incremental output	1~8 opposites	-	1~8,10,12,14,16 poles
PWM output	-	9~12bit	9~12bit
Absolute value Angle	12bit	14bit	14bit
Communication interface	I ² C	I ² C/3-wire SPI/ 4-wire PSI	I ² C/3-wire SPI/ 4-wire PSI
Analog output	10%~90%VDD	Rail to rail	Rail to rail
Encapsulation form	SOP-8	SOP-8 , QFN3*3	SOP-8 , QFN3*3

▪ High speed magnetic Angle coding IC-CC6835

The latest generation of high-speed magnetic angle-coded IC achieves Angle detection accuracy within $\pm 0.1^\circ$ through integrated powerful signal processing circuit, and can support up to 120,000 RPM. The incr-

emental ABZ output can reach the highest resolution of 16384 lines, in the field of industrial servo applications can replace the traditional 2500 lines and 17 bit photoelectric encoder, absolute output of 21 bits, can greatly save costs for customers and significantly improve the reliability of use.

Recommended application: Closed-loop stepper motor control, industrial servo motor control and other high performance requirements.

	CC6701	CC6816	CC6825	CC6815
Induction principle	Differential hall	AMR	AMR	AMR
Working voltage VDD	3.3~5.0V	3.3~5.0V	3.3~5.0V	3.3~5.0V
Induced magnetic field requirement	20mT~100mT	>30mT	>30mT	>30mT
Measuring range	0~360 ° +Z axis press induction PUSH output foot	0~360 °	0~360 °	0~360 °
Power consumption	10mA	10mA	10mA	20mA
Operating temperature	-40~125	-40~125	-40~125	-40~125
Linearity INL (typical value)	-0.75 ° <INL<0.75 °	-0.75 ° <INL<0.75 °	-0.5 ° <INL<0.5 °	-0.1 ° <INL<0.1 °
System delay (uniform speed)	<5us	<2us	<2us	1us~10us
Noise	0.01 ° rms	0.003 ° rms	0.002 ° rms	0.002 ° rms
Maximum support speed	< 55,000 RPM	<25000RPM	<25000RPM	<120000RPM
ABZ incremental output	value ranges from 1 to 1024	value ranges from 1 to 1024	value ranges from 1 to 4096	value ranges from 1 to 16384
UVW incremental output	1~16 pairs of arbitrary programmable	1~16 pairs of arbitrary programmable	1~16 pairs of arbitrary programmable	1~16 pairs of arbitrary programmable
PWM output	12bit	12bit	12bit	12bit
PWM output	14bit	14bit	18bit	21bit
Communication interface	I ² CRead and write; SSI read only	3 line SPI/4 line SPI	3 line SPI/4 line SPI	4-wire SPI
Encapsulation form	SOP-8 , QFN3*3	SOP-8	TSSOP-16	TSSOP-16

▪ On-line programming Angle position IC-CC6501

CC6501 is an output programmable magnetic angular position chip developed for the automotive market. The CC6501 provides 0~360 ° editable analog linear or PWM output while also supporting SPI or single wire (OWI) communication modes. Analog linear output supports up to 4 point editing and high and low clamp voltage editing, suitable for a variety of practical environments with strict Angle control scenarios.

The CC6501 has passed the reliability certification of AECQ-100. The chip can withstand high voltages up to $\pm 30V$ between the power terminal and ground, and the output terminal can withstand high voltages up to 18V between ground and has strong load driving capability and overcurrent protection mechanism. The CC6501 offers single-channel SOP-8 and dual-channel TSSOP-16 (secure redundancy) packages.

Recommended application: EGR valves, throttle valves, electronic accelerator pedals, knob shifters, etc.

	CC6501
Principle of magnetic induction	AMR
Detection Angle range	0 ° ~360 °
Dual Die redundancy design package	Yes
Automotive electronic reliability	AEC-Q100
Power supply overvoltage protection	$\pm 30V$
Output overvoltage protection	18V
Operating voltage	4.5V~5.5V
Power consumption	Single channel 6mA, double channel 12mA
Output noise	<1.5mVrms
Programming mode	Output single-line programming or SPI programming
Operating temperature range	-40~150
Analog output curve programming	Any 4 points
PWM output	Yes
Digital interface	3-wire SPI, single-wire OWI
Absolute accuracy of Angle	$\pm 1^\circ$ (0~360 ° , not specially programmed)

- Off-axis magnetic Angle coding IC-CC6828

CC6828 is an Angle encoder chip based on anisotropic reluctance AMR principle. It can support two mounting modes in shaft simultaneously. Compared with the application in the shaft which needs to occupy a end face of the motor shaft, the off-shaft installation is more flexible and more suitable for robot joints, AGV motor and other applications.

The CC6828 provides incremental ABZ, UVW output and absolute value PWM, 4-wire SPI (1 pair of magnets or magnetic rings to achieve absolute value) output. The CC6828 has a powerful calibration and compensation algorithm built in, which is designed for the chip sensing during off-axis installation and for the INL linearity loss caused by the malformation of the magnetic field induced by the chip during off-axis installation.

	CC6828
Induction principle	AMR
Installation mode	On or off axis
Working field range	>30mT
Operating voltage	3.3~5.0V
Output Angle accuracy	-1 ° < Typical value <1 °
System delay	1us~10us
Incremental output	ABZ/UVW
Communication interface	4-wire SPI
ABZ output resolution	1 to 1024 The value can be edited
UVW output resolution	1~16 pairs of poles can be edited
PWM output	12bit
Absolute value output	17bit Angle data; 12bit PWM
Maximum support speed	120000 RPM (@1 polar ring)
Encapsulation form	QFN4x4-24



Encapsulation form

Packages		Description
	STO-23	tape&reel packaging (3000pcs/bag)
	STO-23-6L	tape&reel packaging (3000pcs/bag)
	Small STO-23	tape&reel packaging (3000pcs/bag)
	SOP-8	tape&reel packaging (3000pcs/bag)
	SOP-16W	tape&reel packaging (1000pcs/bag)
	SOP-553	tape&reel packaging (3000pcs/bag)
	QFN-16 (3*3mm)	tape&reel packaging (1000pcs/bag)



Encapsulation form

Packages		Description
	TSSOP-16	tube packaging (60pcs/tube) or tape&reel packaging (1000pcs/bag)
	CB-2-3	tube packaging (1000pcs/box)
	Flat TO-92	bulk packaging (1000pcs/bag)
	Flat TO-94	bulk packaging (1000pcs/bag)
	DFN1608	tape&reel packaging (10000pcs/bag)
	DFN2*3	tape&reel packaging (3000pcs/bag)
	DFN1616	tape&reel packaging (3000pcs/bag)
	WLCSP	tape&reel packaging (3000pcs/bag)

STO-23

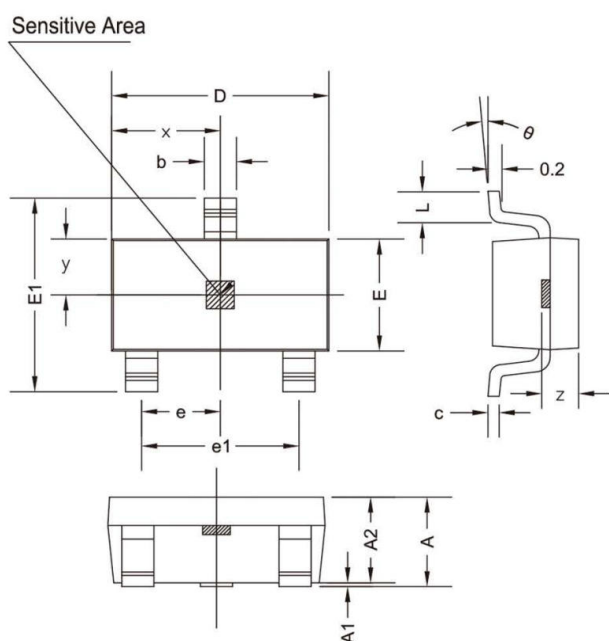
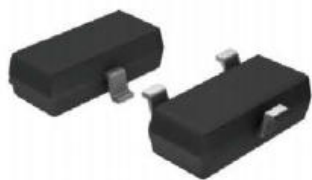

Characteristic	Dimensions are measured in millimeters		Dimensions are measured in feet	
	Minimum	Maximum	Minimum	Maximum
A	1.050	1.250	0.041	0.049
A1	0.000	0.100	0.000	0.004
A2	1.050	1.150	0.041	0.045
b	0.300	0.500	0.012	0.020
C	0.100	0.200	0.004	0.008
D	2.820	3.020	0.111	0.119
E	1.500	1.700	0.059	0.067
E1	2.650	2.950	0.104	0.116
e	0.950 TYP		0.037 TYP	
e1	1.800	2.000	0.071	0.079
L	0.300	0.600	0.012	0.024
	0 °	8 °	0 °	8 °
X	1.460TYP		0.057TYP	
Y	0.800TYP		0.032TYP	
Z	0.600TYP		0.024TYP	

Small STO-23

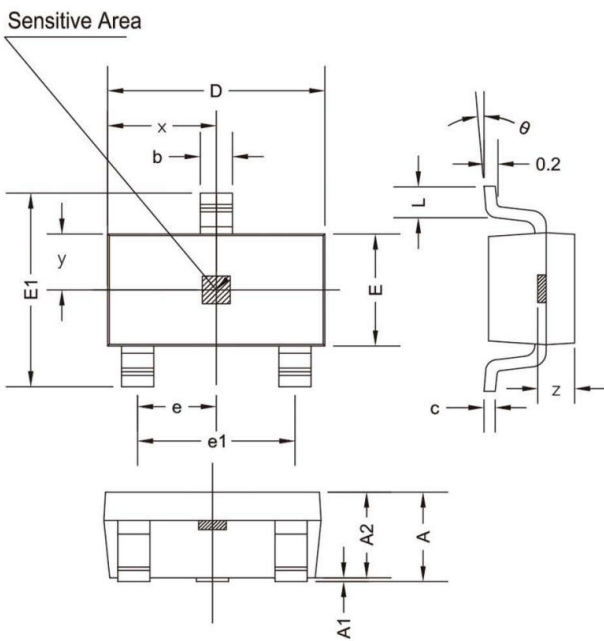

Characteristic	Dimensions are measured in millimeters		Dimensions are measured in feet	
	Minimum	Maximum	Minimum	Maximum
A	0.900	1.250	0.035	0.045
A1	0.000	0.100	0.000	0.004
A2	0.900	1.150	0.035	0.041
b	0.300	0.500	0.012	0.020
C	0.080	0.200	0.003	0.006
D	2.800	3.020	0.110	0.118
E	1.200	1.700	0.047	0.055
E1	2.250	2.950	0.089	0.100
e	0.950 TYP		0.037 TYP	
e1	1.800	2.000	0.071	0.079
L	0.550 REF		0.037 REF	
L1	0.300	0.500	0.012	0.020
	0 °	8 °	0 °	8 °
X	1.460TYP		0.057TYP	
Y	0.650TYP		0.026TYP	
Z	0.500TYP		0.020TYP	

STO-23-6L

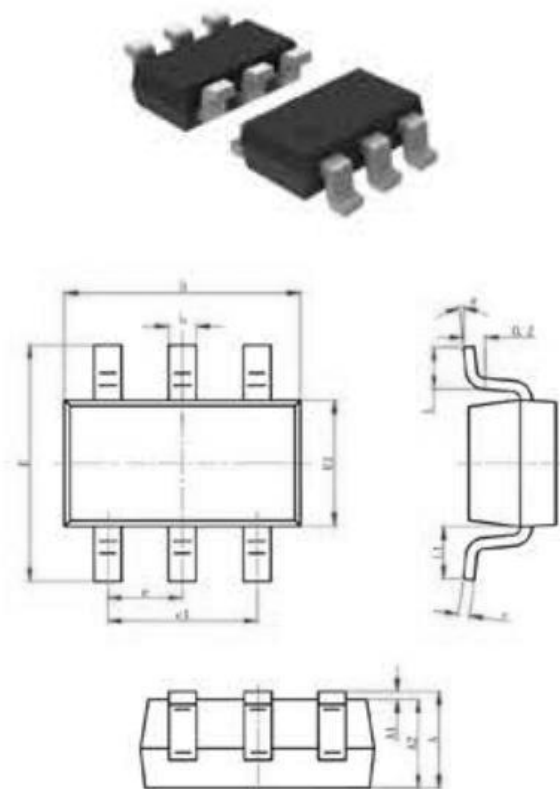

Characteristic	Dimensions are measured in millimeters		Dimensions are measured in feet	
	Minimum	Maximum	Minimum	Maximum
A	1.050	1.250	0.041	0.049
A1	0.000	0.100	0.000	0.004
A2	1.050	1.150	0.041	0.045
b	0.300	0.500	0.012	0.020
C	0.100	0.200	0.004	0.008
D	2.820	3.020	0.111	0.119
E1	2.650	1.700	0.059	0.067
E	1.500	2.950	0.104	0.116
e	0.950 TYP		0.037 TYP	
e1	1.800	2.000	0.071	0.079
L	0.300	0.600	0.012	0.024
L1	0.600 TYP		0.024 TYP	
	0 °	8 °	0 °	8 °

SOP-8

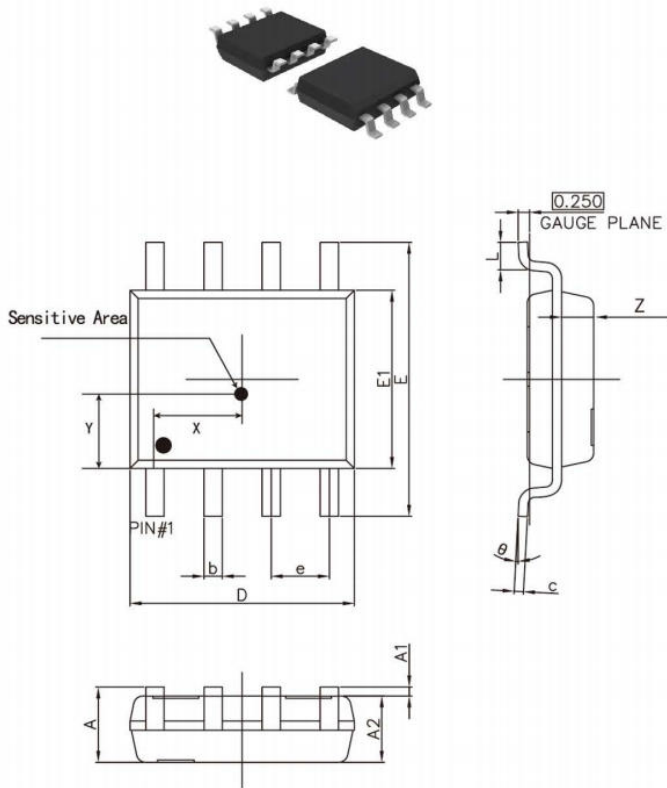

Characteristic	Dimensions are measured in millimeters		Dimensions are measured in feet	
	Minimum	Maximum	Minimum	Maximum
A	1.350	1.750	0.053	0.069
A1	0.100	0.250	0.004	0.010
A2	1.350	1.550	0.053	0.061
b	0.330	0.510	0.013	0.020
C	0.170	0.250	0.007	0.010
D	4.700	5.100	0.185	0.201
E	5.800	6.200	0.228	0.244
E1	3.800	4.000	0.150	0.157
e	1.270 (BSC)		0.050(BSC)	
L	0.400	0.800	0.016	0.031
	0 °	8 °	0 °	8 °
X	1.97	2.27	0.078	0.089
Y	1.34	1.70	0.053	0.067
Z	0.42	0.62	0.016	0.024

SOT-553

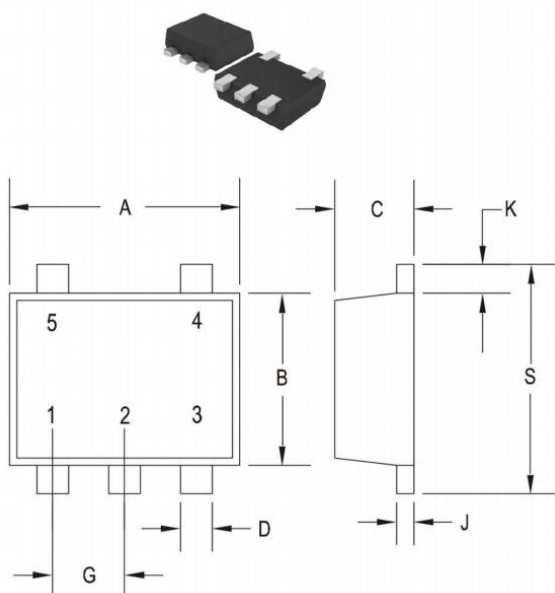

Characteristic	Dimensions are measured in millimeters		Dimensions are measured in feet	
	Minimum	Maximum	Minimum	Maximum
A	1.500	1.700	0.059	0.067
B	1.100	1.300	0.043	0.051
C	0.525	0.600	0.021	0.024
D	0.170	0.270	0.007	0.011
G	0.450	0.550	0.018	0.022
J	0.090	0.160	0.004	0.006
K	0.100	0.300	0.004	0.012
S	1.500	1.700	0.059	0.067

SOP-16W

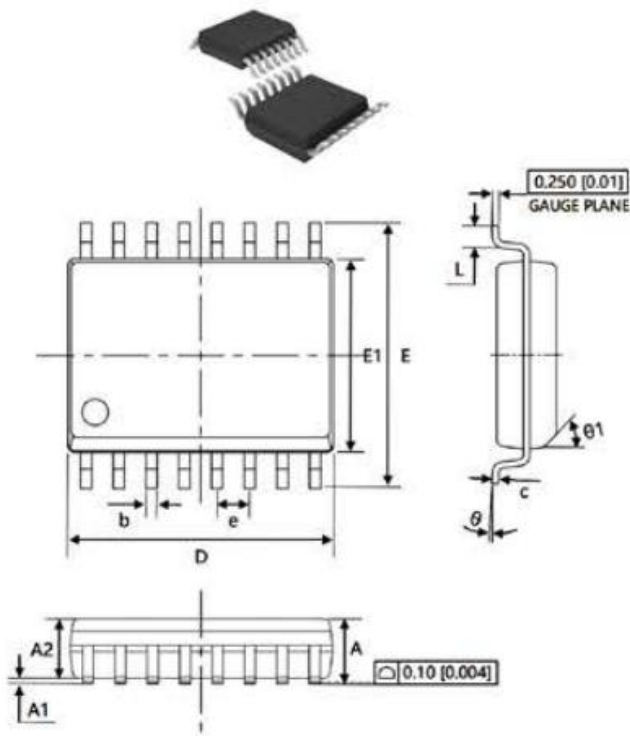

Characteristic	Dimensions are measured in millimeters		Dimensions are measured in feet	
	Minimum	Maximum	Minimum	Maximum
A	2.350	2.650	0.093	0.104
A1	0.100	0.300	0.004	0.012
A2	2.050	2.550	0.081	0.100
b	0.330	0.510	0.013	0.020
C	0.230	0.320	0.009	0.013
D	10.10	10.50	0.398	0.413
E	10.00	10.63	0.394	0.419
E1	7.400	7.600	0.291	0.299
e	1.270 (BSC)		0.050(BSC)	
L	0.400	1.270	0.016	0.050
	0 °	8 °	0 °	8 °
	45 °		45 °	

TSSOP-16

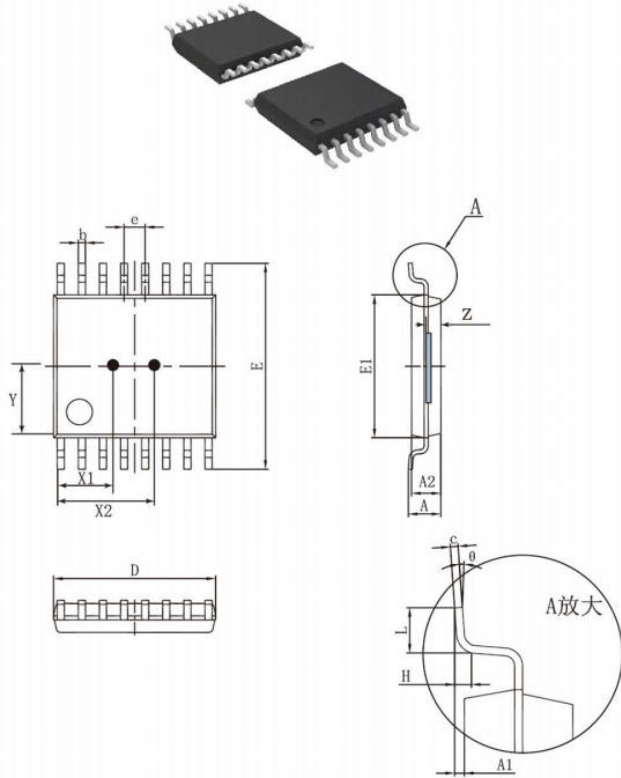

Characteristic	Dimensions are measured in millimeters		Dimensions are measured in feet	
	Minimum	Maximum	Minimum	Maximum
D	4.900	5.100	0.193	0.201
E	6.250	6.550	0.246	0.258
b	0.190	0.300	0.007	0.012
c	0.090	0.200	0.004	0.008
E1	4.300	4.500	0.169	0.177
A		1.200		0.047
A2	0.800	1.000	0.031	0.039
A1	0.050	0.150	0.002	0.006
e	0.65 (BSC)		0.050(BSC)	
L	0.500	0.700	0.020	0.028
H	0.25 TYP		0.01 TYP	
	1 °	7 °	1 °	7 °
X1	1.650	1.890	0.065	0.074
X2	3.110	3.350	0.122	0.132
X1	2.080	2.320	0.081	0.093
X2	0.210	0.370	0.016	0.024

QFN-16(3mm*3mm)

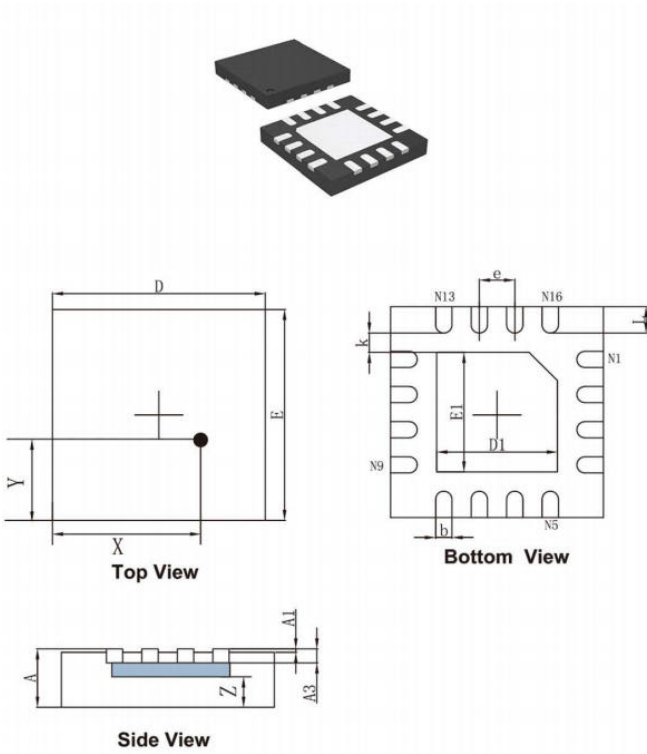

Characteristic	Dimensions are measured in millimeters		Dimensions are measured in feet	
	Minimum	Maximum	Minimum	Maximum
A	0.700	5.100	0.028	0.031
A1	0.000	0.050	0.000	0.002
A3	0.203REF		0.008REF	
D	2.900	3.100	0.114	0.122
E	2.900	3.100	0.114	0.122
D1	1.600	1.800	0.063	0.071
E1	1.600	1.800	0.063	0.071
k	0.275REF		0.011REF	
b	0.180	0.300	0.007	0.012
e	0.500REF		0.020REF	
L	0.300	0.500	0.012	0.020
X	1.690	1.990	0.066	0.078
Y	1.110	1.410	0.043	0.055
Z	0.420	0.620	0.016	0.024

CB-2-3

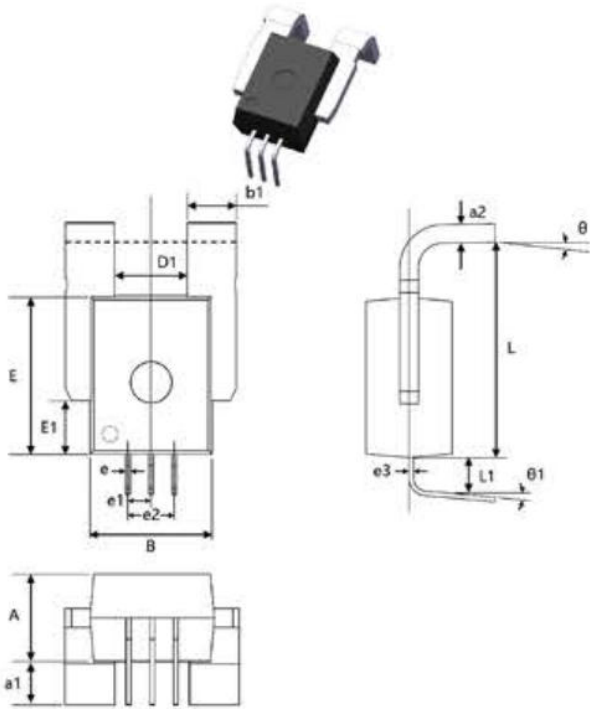

Characteristic	Dimensions are measured in millimeters		Dimensions are measured in feet	
	Minimum	Maximum	Minimum	Maximum
A	6.900	7.100	0.272	0.280
a1	3.350	3.650	0.132	0.144
a2	1.400	1.600	0.055	0.063
B	9.900	10.10	0.390	0.398
b1	3.850	4.150	0.152	0.163
D1	5.900	6.100	0.232	0.240
E	12.90	13.10	0.508	0.516
E1	4.300	4.500	0.169	0.177
L	18.03	18.33	0.710	0.722
L1	2.750	3.050	0.108	0.120
e	0.506	0.519	0.020	0.020
e1	1.905(BSC)		0.075(BSC)	
e2	3.810(BSC)		0.150(BSC)	
e3	0.379	0.381	0.015	0.024
	6.5 °	10.5 °	6.5 °	10.5 °
1	7.5 ° (BSC)		7.5 ° (BSC)	

Flat TO-92

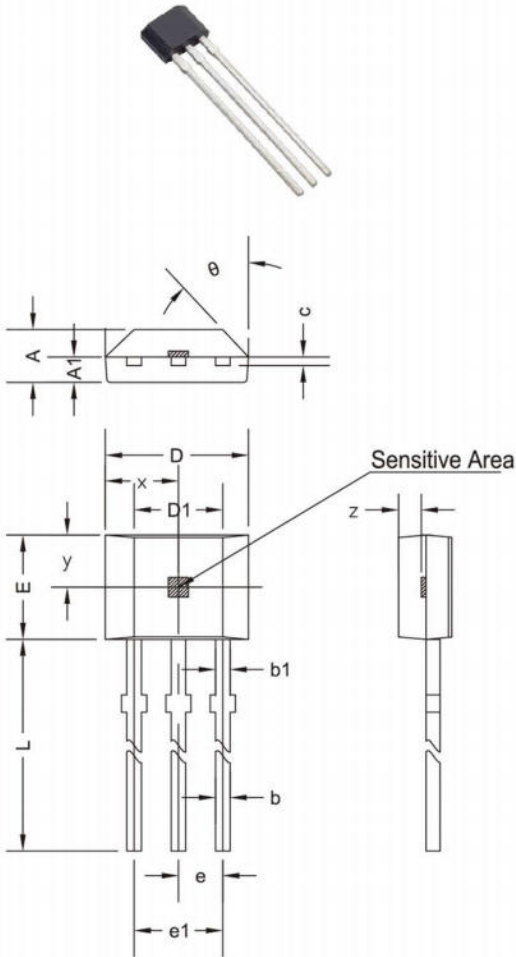

Characteristic	Dimensions are measured in millimeters		Dimensions are measured in feet	
	Minimum	Maximum	Minimum	Maximum
A	1.420	1.620	0.056	0.064
A1	0.660	0.860	0.026	0.034
b	0.350	0.480	0.013	0.019
b1	0.400	0.510	0.016	0.020
C	0.330	0.510	0.013	0.020
D	3.900	4.100	0.154	0.161
D1	2.280	2.680	0.090	0.106
E	3.050	3.250	0.120	0.128
e	1.270TYP		0.050TYP	
e1	2.440	2.640	0.096	0.104
L	14.350	14.750	0.565	0.581
	45 ° TYP		45 ° TYP	
x	2.025TYP		0.080TYP	
y	1.545TYP		0.061TYP	
z	0.500TYP		0.020TYP	

Flat TO-94

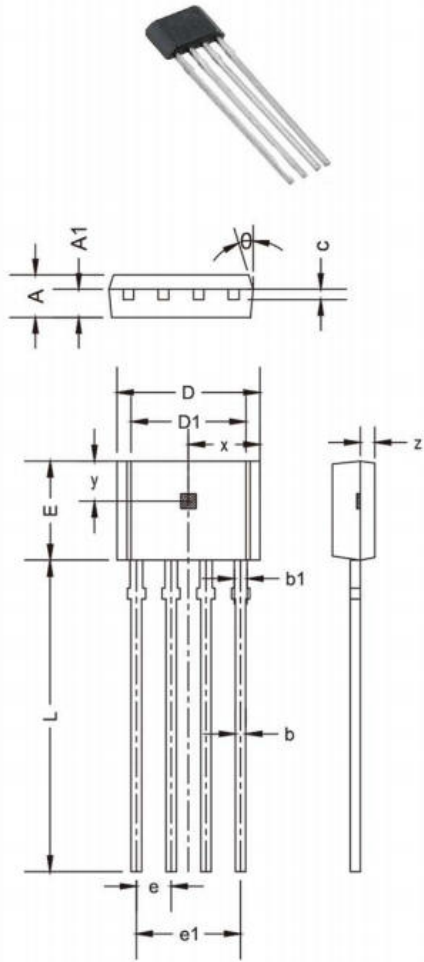

Characteristic	Dimensions are measured in millimeters		Dimensions are measured in feet	
	Minimum	Maximum	Minimum	Maximum
A	1.420	1.660	0.056	0.065
A1	0.660	0.860	0.026	0.034
b	0.350	0.480	0.014	0.019
b1	0.400	0.650	0.016	0.026
C	0.360	0.510	0.014	0.020
D	5.100	5.320	0.201	0.210
D1	4.100	4.300	0.161	0.169
E	3.550	3.750	0.140	0.147
e	1.267	1.273	0.050	0.050
e1	3.780	3.840	0.149	0.151
L	13.500	15.500	0.531	0.610
x	2.605TYP		0.103TYP	
y	1.825TYP		0.072TYP	
z	0.500TYP		0.020TYP	
	10 °	12 °	10 °	12 °

DFN1608

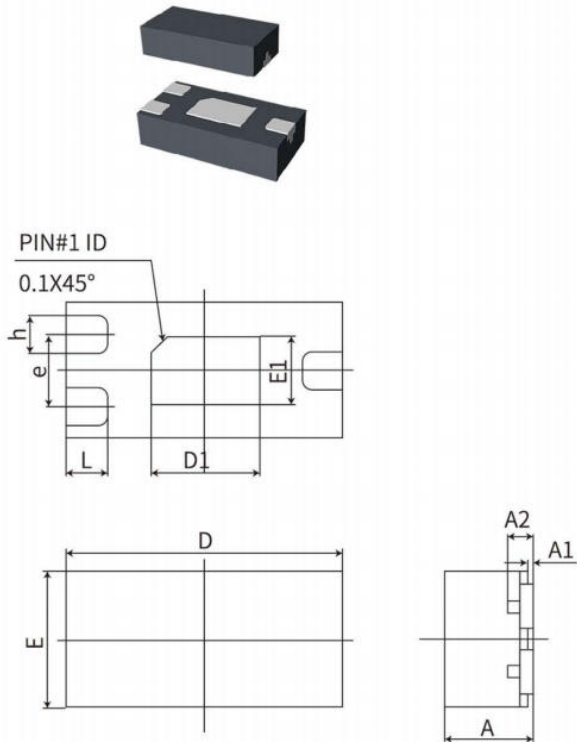

Characteristic	Dimensions are measured in millimeters		Dimensions are measured in feet	
	Minimum	Maximum	Minimum	Maximum
A	0.450	0.550	0.018	0.022
A1	0.000	0.050	0.000	0.002
A2	0.150 REF		0.006 REF	
D	1.550	1.650	0.061	0.065
E	0.750	0.850	0.030	0.033
D1	0.580	0.680	0.023	0.027
E1	0.350	0.450	0.014	0.018
b	0.170	0.270	0.007	0.011
e	0.420 TYP		0.017 TYP	
L	0.185	0.285	0.007	0.011

DFN1616

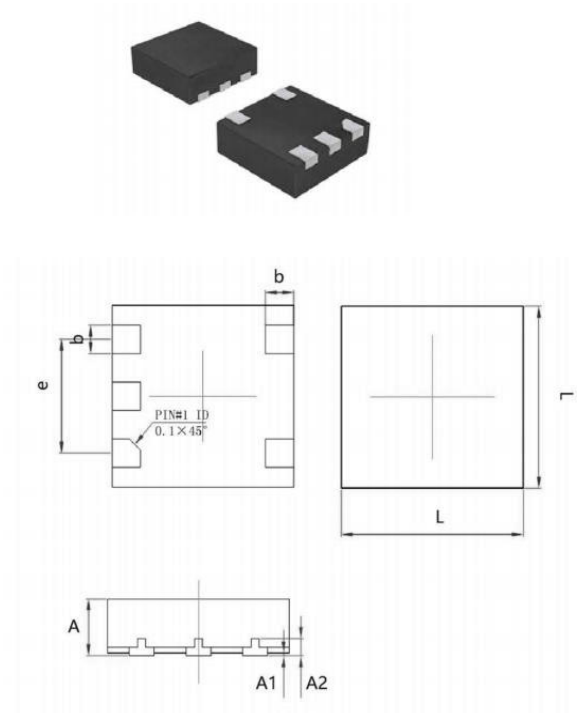

Characteristic	Dimensions are measured in millimeters		Dimensions are measured in feet	
	Minimum	Maximum	Minimum	Maximum
A	0.450	0.550	0.018	0.022
A1	0.000	0.050	0.000	0.002
A2	0.150 TYP		0.006 TYP	
L	1.550	1.650	0.061	0.065
b	0.200	0.300	0.008	0.012
e	1.000 TYP		0.039 TYP	

DFN2*3

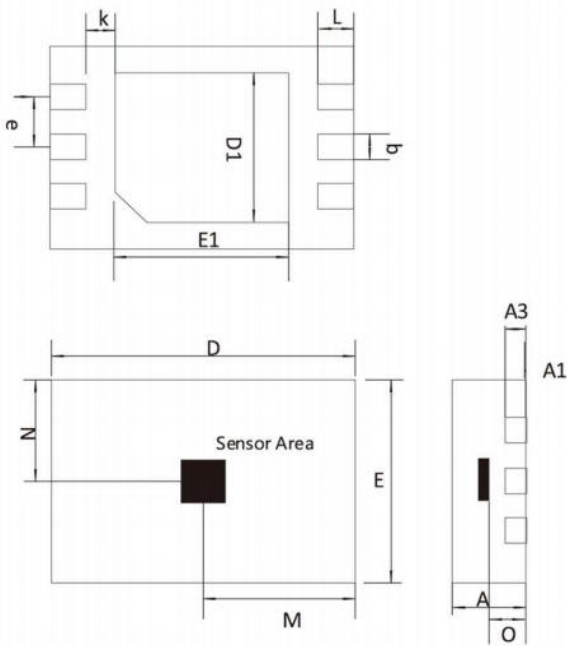

Characteristic	Dimensions are measured in millimeters		Dimensions are measured in feet	
	Minimum	Maximum	Minimum	Maximum
A	0.700	1.660	0.028	0.031
A1	0.000	0.860	0.000	0.002
A3	0.203 REF		0.008 REF	
D	2.950	0.650	0.116	0.120
E	1.950	0.510	0.077	0.081
D1	1.400	5.320	0.055	0.063
E1	1.600	4.300	0.063	0.071
b	0.200	3.750	0.008	0.012
e	0.500 TYP		0.020 TYP	
k	0.200 MIN		0.008 MIN	
L	0.300	0.400	0.012	0.016
M	1.490TYP		0.060TYP	
N	0.800TYP		0.032TYP	
O	0.500TYP		0.020TYP	
Sensor Area	0.660*0.660*0.120		0.026*0.026*0.005	

WLCSP

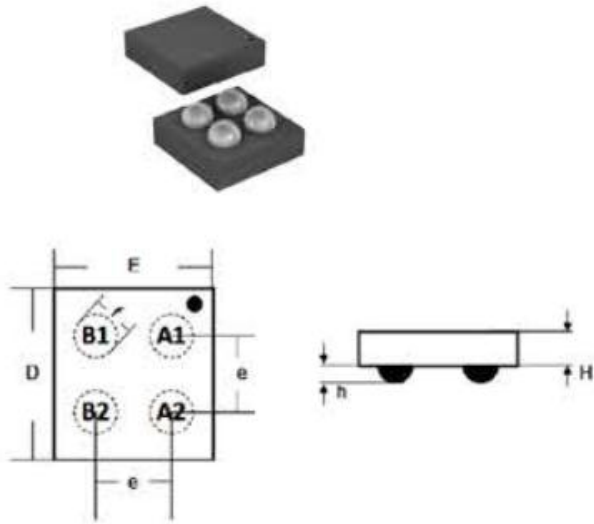

Characteristic	Dimensions are measured in millimeters		Dimensions are measured in feet	
	Minimum	Maximum	Minimum	Maximum
E	0.745	0.795	0.030	0.032
D	0.775	0.825	0.031	0.033
e	0.400 TYP		0.016 TYP	
f	0.200 TYP		0.008 TYP	
H	0.312	0.368	0.012	0.015
h	0.060 TYP		0.002 TYP	

DISCLAIMER

Warning

LIFE OR PROPERTY RISK

- Please ensure that this product has been designed as part of whole system and already considered related risks, make sure the product has the correct ratings and is designed based on the entire system. It must not be used when applications related to serious life or property damage risks.

Failure to follow this instruction can result in death or serious injury.

Warning

PERSONAL INJURY

- DO NOT USE these products as safety or emergency stop devices or in any other application where failure of the product could result in personal injury.

Failure to follow this instruction can result in death or serious injury.

Warning

MISUSE OF DOCUMENTATION

- The information presented in this product sheet is for reference only. Do not use this document as a product installation guide.
- Complete installation, operation, and maintenance information is provided in the instructions supplied with each product.

Failure to follow this instruction can result in death or serious injury.

Warranty/Remedy

Banning warrants goods of its manufacture as being free of defective materials and faulty workmanship during the applicable warranty period. Banning's standard product warranty applies unless agreed to otherwise by Banning in writing; please refer to your order acknowledgment or consult your local sales office for specific warranty details. If warranted goods are returned to Banning during the period of coverage, Banning will repair or replace, at its option, without charge those items that Banning, in its sole discretion, finds defective. The foregoing is buyer's sole remedy and is in lieu of all other warranties, expressed or implied, including those of merchantability and fitness for a particular purpose. In no event shall Banning be liable for consequential special, or indirect damages.

While Banning may provide application assistance personally, through our literature and the Banning web site, it is buyer's sole responsibility to determine the suitability of the product in the application.

Specifications may change without notice. The information we supply is believed to be accurate and reliable as of this writing. However, Banning assumes no responsibility for its use.

SALES & SERVICE

Banning serves its clients through a worldwide network of sales offices, agents and distributors. For application assistance specifications, prices or names with the nearest authorized dealer, please contact your sales specialist or contact us directly:

Banning (Nanjing) Sensing Technology Co., Ltd.

Nanjing, Pukou District, Longtai Road, No. 16
Building C2, 3rd Floor

TEL : 400-7181-886

TEL : 025-5829 5589



WeChat



Invoice

Official Website : www.bnsens.com

Service Hotline : 400-7181-886

Official mailbox : sales@banningsensor.com

© 2021 Banning (Nanjing) Sensing Technology Co., Ltd.

INTEGRITY
INTERNATIONAL
INNOVATION

BANNING